

DP100

User's manual

DOTECH
SENSING & CONTROL

DOTECH INC.

6F, JOONGANG-ILBO B/D, 30, Dongsan-ro, Danwon-gu,
Ansan-si, Gyeonggi-do, KOREA
Phone: +82-31-495-3767, Fax: +82-31-495-3917
www.dotech21.com



1. This product may cause an electric shock in handling. Please do not attempt to open it with power turned on.
 2. This product should be installed in a place fixed secured by a rack or panel.
 3. This product can be used under the following environmental condition.
 - ① Indoor ② Pollution Degree 2 ③ At an altitude of 2000m or below
 4. Power input must be within the designated ranges.
 5. To turn on or turn off power supply for this product, please the circuit breaker or switch of a standard product of IEC 60947-1 or IEC 60947-3 product and install it within a close distance allowing convenient operation by user.
 6. Please be understood that if this product is dismantled or modified discretionary, after sales service will not be able to be provided.
 7. An output wire to be used for this product should be inflammable grade FV1 (V-1 grade or above), the thickness of the wire should be AWG No. 20 or above(0.50mm²).
 8. In order to prevent it from an inductive noise, please maintain the high-voltage wire and power wire separated.
 9. Please avoid installing the product in a place where a strong magnetism, noise, severe vibration and impact exist.
 10. When extending the sensor wire, use a shield wire and do not extend it unnecessary long.
 11. The sensor wire and signal wire should be away from the power and load wires using conduits separately installed.
 12. Please avoid using the product near a device generating strong high frequency noise (high-frequency welding machine, high-frequency sewing machine, high-frequency radiotelegraph, high capacity SCR controller)
 13. Product's damages other than those described in the guarantee conditions provided by the manufacturer shall not be responsible by us.
 14. If this unit is used to control machineries (Medical equipment, vehicle, train, airplane, combustion apparatus, entertainment, processing and transportation equipment, elevator and various safety device etc.) enabling to effect on human or property, it is required to install fail-safe device.
- ※ The aforementioned precautions must be observed, and if you fail to do so, it may cause a product's breakdown.
 ※ The specifications, dimensions, and etc. are subject to change for enhancement without a prior notice.

1. Overview



□ Features

DP100 with a built in innovative CMOS type sensor which has high resolution and accuracy, specifically in low differential pressure range, and guarantee an excellent long term reliability by temperature compensation and pressure calibration through its own circuit
 This model is ideal for HVAC, semiconductor equipment, medical appliance and etc due to good design and high efficiency against the cost.

: Basic Specifications

Items	Description	
Power	17 ~ 24 Vdc / Vac, 50/60Hz (-A1 model) 10 ~ 24Vdc / Vac, 50-60Hz (-R4 model)	
Power Consumption	MAX 5VA	
Connection	Screw Terminal, Wire Range : 24~12AWG	
Diff. Pressure Range	DP100-XX	-500 ~ 500 Pa
	DP100-XX-125	-125 ~ 125 Pa
	DP100-XX-25	-25 ~ 25 Pa
Span Accuracy	± 3 %	
Zero point Accuracy	± 0.2 Pa	
IP rating	IP65	
Operation Condition	Temp. - 10~50°C, (Non condensation)	
Storage Condition	Temp. - 20~60°C, Humidity 90%RH or less	

: Ordering Guide

Model name	Description
DP100-A1	Measuring Range : -500 ~ 500Pa 4~20mA Transmission Output
DP100-R4	Measuring Range : -500 ~ 500Pa RS485 / MODBUS RTU MODE
DP100-A1R4	Measuring Range : -500 ~ 500Pa 4~20mA Transmission Output, RS485
DP100-A1-125	Measuring Range : -125 ~ 125Pa 4~20mA Transmission Output
DP100-R4-125	Measuring Range : -125 ~ 125Pa RS485 / MODBUS RTU MODE
DP100-A1R4-125	Measuring Range : -125 ~ 125Pa 4~20mA Transmission Output, RS485
DP100-A1-25	Measuring Range : -25 ~ 25Pa 4~20mA Transmission Output
DP100-R4-25	Measuring Range : -25 ~ 25Pa RS485 / MODBUS RTU MODE
DP100-A1R4-25	Measuring Range : -25 ~ 25Pa 4~20mA Transmission Output, RS485

: Packing



DP100



User's manual

※ Silicon Tube Φ6.0 * 3.0 2M (※ Standard scope of supply)

□ Display range for pressure

Unit	Measuring Range	Display range of decimal point (Automatic Switching)
Pa	-500 ~ 500	-199.9 ~ 500.0 / -500 ~ -200
mbar / hPa	-5 ~ 5	-1.999 ~ 5.000 / -5.00 ~ -2.00
kPa	-0.5 ~ 0.5	0.000 ~ 0.500 / -0.50 ~ -0.01
mmAq	-50 ~ 50	-19.99 ~ 50.00 / -50.0 ~ -20.0
inchH ₂ O	-2 ~ 2	-1.999 ~ 2.000 / -2.00
mmHg	-3.75 ~ 3.75	-1.999 ~ 3.750 / -3.75 ~ -2.00
inchHg	-0.15 ~ 0.15	-0.150 ~ 0.150

2. Installation

: Dimension & Installation

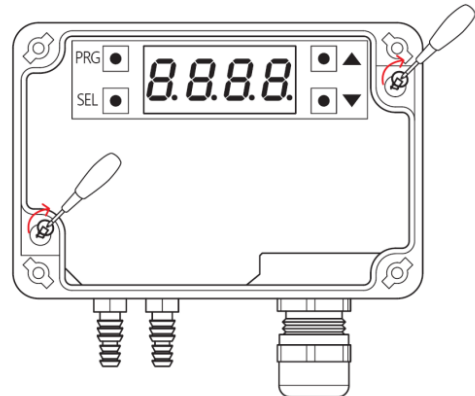
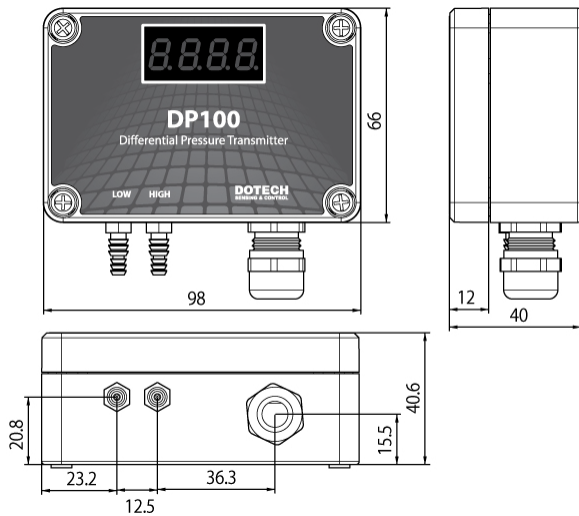

- Remove front case and fasten back plate of product using 2 screws.
- Put a lid on back plate and tighten up the spring lock screw after finishing mount.

: Wiring

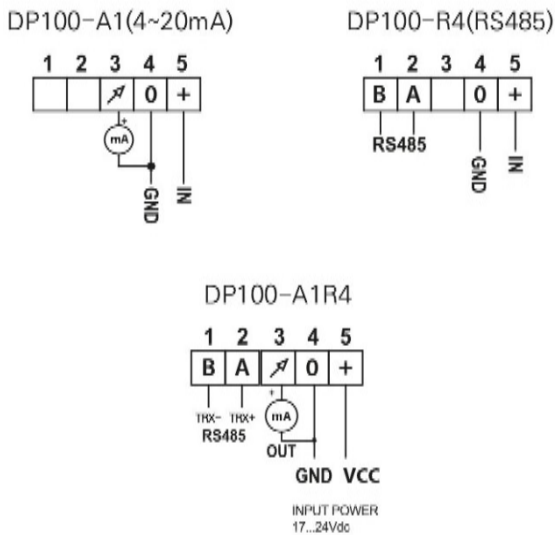

: Terminal

No.		Description
DP100-A1		
1	None	
2	None	
3	SIGNAL	4 ~20mA + Signal Output
4	GND	GND
5	POWER	+Power input 17 – 24 Vdc / Vac, 50/60Hz
DP100-R4		
1	RS485	TRX - Signal
2		TRX + Signal
3	None	
4	GND	GND
5	POWER	+Power input 17 – 24 Vdc/Vac, 50/60Hz
DP100-A1R4		
1	RS485	TRX - Signal
2		TRX + Signal
3	SIGNAL	4 ~20mA + Signal Output
4	GND	GND
5	POWER	+Power input 17 – 24 Vdc / Vac, 50/60Hz

3. User Interface

: Lamp & Operation Button



Button	Description
PRG	Program setup and check unit of display Press twice successively when clearing alarm
SEL	Selection and storage
▲	Move menu and increase set value
▼	Move menu and decrease set value Identify peak value when pressing for 0.5 seconds. Initialize peak value when pressing 5 seconds.
PRG + ▼	Initialization when pressing simultaneously for 10 seconds
▲ + ▼	Internal temperature of differential pressure sensor

4. Parameter

: Parameter change

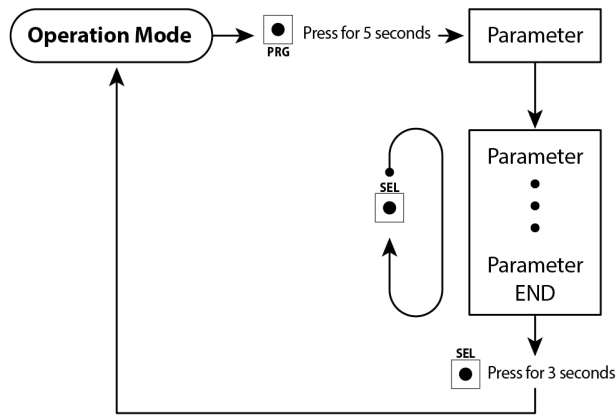

- Press PRG button for 5 seconds to change parameters.
- Press PRG button at parameter setup to move to next parameter.
- Movement to next menu and storage of set value during parameter setup are performed by SEL button.
- Set value will be flickering in every 0.5 seconds and change set value using ▲ key or ▼ key.
- Differential pressure will be displayed if pressing SEL button for 3 seconds after finishing parameter setup.

: Setting Group Table

Address	Description	Code	Unit	Step	Min.	Max.	Default
4 0077	Selection of unit of pressure	<i>Unit</i>	<i>PP</i> (0) = Pa <i>mbar</i> (1) = mbar <i>KPP</i> (2) = KPa <i>hPP</i> (3) = hPa <i>mmPP</i> (4) = mmH ₂ O <i>inch</i> (5) = inchH ₂ O <i>mmHg</i> (6) = mmHg <i>inchG</i> (7) = inchHG				<i>PP</i> (0)
4 0080	Offset setup (※1)	<i>oFS</i>	Pa	0.1	-199.9	199.9	0.0
4 0081	Decimal point display setup (※2)	<i>dP</i>	<i>oFF</i> (0)		<i>on</i> (1)		<i>oFF</i> (0)
4 0082	Span gain setup (※3)	<i>SPn</i>	-	0.1	0.000	9.999	1.000
4 0083	Sensor input filter setup (※4)	<i>SFL</i>	-	0.1	0.1	5.0	0.5
4 0084	Sensor value display cycle (※5)	<i>Sdt</i>	Sec.	0.1	0.0	5.0	0.5
4 0086	Comm. ID setup (-R4 model)	<i>id</i>	-	1	1	128	1
4 0087	BPS setup (-R4 model)	<i>bPS</i>	<i>48</i> (0) = 4800	<i>96</i> (1) = 9600	<i>192</i> (2) = 19200	<i>384</i> (3) = 38400	<i>96</i> (1)
	Analog trans. output at 20mA (A1 model)	<i>rEH</i>	-	0.1	-999	999.9	500.0
	Analog trans. output at 4mA (A1 model)	<i>rEL</i>	-	0.1	-999	999.9	0.0

(※1) Offset setup: Correct deviation of differential pressure

(※2) Decimal point display setup: OFF = display decimal point, ON = Display to 1 place of decimals e.g) OFF:1.93, ON:1.9

(※3) Span gain setup: Set gain of differential pressure sensor. Final display value = Measured value + span gain + offset.

(※4) Sensor input filter: In case of frequent hunting of the present differential pressure value, it is corrected by increasing filter value.

(※5) Sensor value display cycle: Set display cycle of present differential pressure value

: (Trip Alarm Message)

No.	Description	Code	Setting details	Operating at detection	Way to clear
1	System fault	<i>SYS</i>	Reset default value and power again.	Immediately stop	Manual
2	Input sensor open / disconnection	<i>oPn</i>	This message will occur if differential pressure has some problem. ※ Request A/S	Immediately stop	Manual
4	Sensor input lower limit	<i>LLL</i>	This message will occur if input of sensor is lower than lower limit (-500Pa).	Immediately stop	Manual
5	Sensor input upper limit	<i>HHH</i>	This message will occur if input of sensor is higher than upper limit (500Pa).	Immediately stop	Manual

※ In case of the above mentioned errors, it will be normally operated once cause of error is solved.

5. Communication Protocol

: Specifications of Communication (-R4 model)

Item	Description
Transmission line connection	Multiple line
Communications method	RS-485 (2-wire, half-duplex)
Baud-rate	4800, 9600, 19200, 38400 BPS default 9600 BPS
Parity, Data, Stop bit	None, 8 Data, 1 Stop
Protocol Type	Modicon Mod-Bus RTU MODE
Function Code	Read HOLD REGISTERS (0x03) / Preset Single Register (0x06)
Maximum Read Word	32 Word
Media Type	BELDEN 9841 / 9842, LG LIREV-AMESB
Poll interval	100msec

: Communication Table for Status

Address	Description	Unit	Type	Size (Word)	DP100	MMI	Scale
4 0061	Measured Diff. Pressure (Applying unit of Pa)	Pa	Analog	INT16	-500.0 ~ 500.0	-5000 ~ 5000	1/10
4 0062	Measured Diff. Pressure (Applying unit of mbar)	mbar	Analog	INT16	-5.000 ~ 5.000	-5000 ~ 5000	1/1000
4 0063	Measured Diff. Pressure (Applying unit of kPa)	kPa	Analog	INT16	-0.500 ~ 0.500	-500 ~ 500	1/1000
4 0064	Measured Diff. Pressure (Applying unit of hPa)	hPa	Analog	INT16	-5.000 ~ 5.000	-5000 ~ 5000	1/1000
4 0065	Measured Diff. Pressure (Applying unit of mmH2O)	mmH2O	Analog	INT16	-50.00 ~ 50.00	-5000 ~ 5000	1/100
4 0066	Measured Diff. Pressure (Applying unit of inchH2O)	inchH2O	Analog	INT16	-2.000 ~ 2.000	-2000 ~ 2000	1/1000
4 0067	Measured Diff. Pressure (Applying unit of mmHg)	mmHg	Analog	INT16	-3.750 ~ 3.750	-3750 ~ 3750	1/1000
4 0068	Measured Diff. Pressure (Applying unit of inchHg)	inchHg	Analog	INT16	-0.15 ~ 0.15	-150 ~ 150	1/1000
4 0106	Status code of product	-	Analog	INT16	Refer to bit status below		
Bit 0	-	-	Digital	Bit			
Bit 1	-	-	Digital	Bit			
Bit 2	-	-	Digital	Bit			
Bit 3	-	-	Digital	Bit			
Bit 4	-	-	Digital	Bit			
Bit 5	-	-	Digital	Bit			
Bit 6	-	-	Digital	Bit			
Bit 7	-	-	Digital	Bit			
Bit 8	-	-	Digital	Bit			
Bit 9	-	-	Digital	Bit			
Bit 10	-	-	Digital	Bit			
Bit 11	-	-	Digital	Bit			
Bit 12	-	-	Digital	Bit			
Bit 13	-	-	Digital	Bit			
Bit 14	Fault of sensor measurement	-	Digital	Bit	0 = Normal	1 = Abnormal	
Bit 15	-	-	Digital	Bit			
4 0107	Displayed differential pressure		Analog	INT16			